



## DuraShiner® CVBR

You already know that automatic tire shining can be a huge money-maker for your wash. But now, that revenue doesn't have to carry the price of high aggravation.

The industry's only award winning tire shiner is now available with brush fill. The DuraShiner CVBR is designed for longer wear and less tear. The soft-tipped nylon brush easily conforms and accommodates all tire sizes, including the most rugged truck tires on the road today, to deliver the perfect shine every time.

With the NEW *Insta-Chem* controls you will also save on chemical consumption and costs. The operator programmable *Insta-Chem* controls allows you to deliver chemical 'on demand' to the tire shine brush as the vehicle is approaching for on-time application and complete wheel coverage with every wash. With no chemical waste between tire shine services your profit stays where it belongs – in your pocket!

Available in electric or hydraulic models and our brush is compatible with water and solvent based tire dressings.



[belangerinc.com](http://belangerinc.com)

DRIVE | CLEAN

# DuraShiner® CVBR

## Insta-Chem Chemical Controls

Programmable chemical controls let you determine when to apply and how much to use for on-time and controlled chemical consumption.

## Extended Pressure Adjustment

Adjustable pressure feature to ensure optimal brush penetration for complete coverage of tire and sidewalls.

DuraShiner® Electric

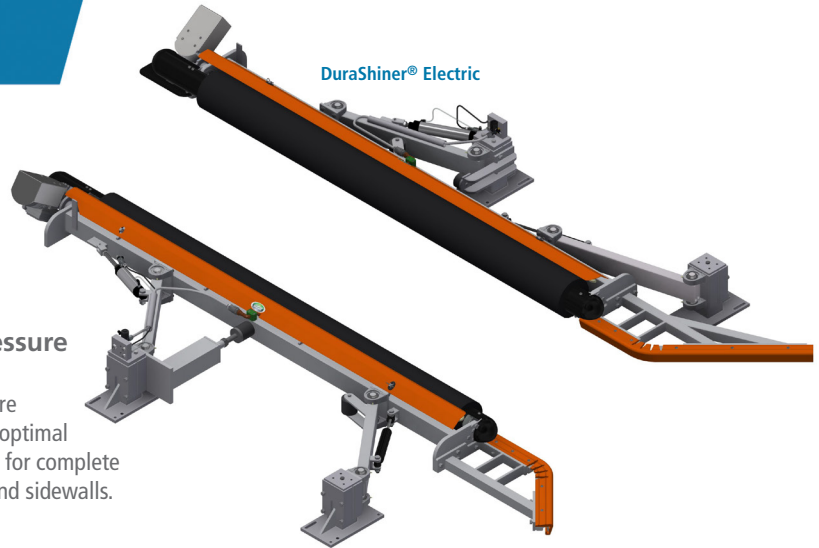

DuraShiner® Hydraulic

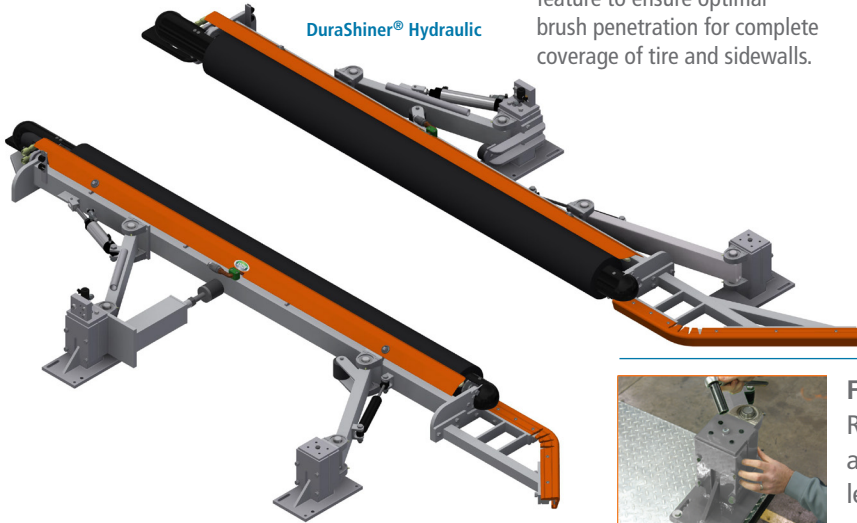

## Long Lasting Nylon Brush Fill

The soft-tipped nylon brushes easily conform to all tire sizes, including the most rugged truck tires on the road today, to deliver the perfect shine every time.

## Fine Tuning Leveling Bolts

Raise or lower tire shiner to adjust the applicator roller contact height, or to level machine front-to-back, simplifying your installation



## REQUIREMENTS

### Physical Examples

Component Height	1'
Minimum Tunnel Width Required	14'
Minimum Tunnel Length Required	15' 3" Full Travel

(\*May be installed fully or partially underneath other compatible pieces of wash equipment) Consult factory for details.

### Utility Examples

Electrical	(1) program function 120 VAC from Controller (1) 120 VAC constant from Controller
Pneumatic	1/4" airline @ 90 PSI minimum, 120 PSI maximum

DuraShiner® Electric Drive	Each assembly equipped with a 3/4 HP, 3-phase electric motor
DuraShiner® Hydraulic Drive	Each assembly equipped with a hydraulic motor requiring 2 GPM @ 1000 PSI, 1/2" supply lines, plumbed in series

Belanger  
1001 Doheny Court  
P.O. Box 5470  
Northville, MI 48167-5470 USA  
[belangerinc.com](http://belangerinc.com) | 248-349-7010

©2021 Belanger Inc. Belanger, Inc. reserves the right to revise specifications, features or designs, and to change or discontinue models at any time without notice or obligation. Prices subject to change without notice.

**BELANGER** 

PART OF  
**OPW**   
VEHICLE WASH SOLUTIONS  
a **DOVER** company

DRIVE | CLEAN